

Accepted Manuscript

Editor's Choice Article

Using a multi-gene approach to infer the complicated phylogeny and evolutionary history of lorises (Order Primates: Family Lorisidae)

Rachel A. Munds, Chelsea L. Titus, Lori S. Eggert, Gregory E. Blomquist

PII: S1055-7903(17)30761-3
DOI: <https://doi.org/10.1016/j.ympev.2018.05.025>
Reference: YMPEV 6176

To appear in: *Molecular Phylogenetics and Evolution*

Received Date: 26 October 2017
Revised Date: 19 April 2018
Accepted Date: 18 May 2018

Please cite this article as: Munds, R.A., Titus, C.L., Eggert, L.S., Blomquist, G.E., Using a multi-gene approach to infer the complicated phylogeny and evolutionary history of lorises (Order Primates: Family Lorisidae), *Molecular Phylogenetics and Evolution* (2018), doi: <https://doi.org/10.1016/j.ympev.2018.05.025>

This is a PDF file of an unedited manuscript that has been accepted for publication. As a service to our customers we are providing this early version of the manuscript. The manuscript will undergo copyediting, typesetting, and review of the resulting proof before it is published in its final form. Please note that during the production process errors may be discovered which could affect the content, and all legal disclaimers that apply to the journal pertain.

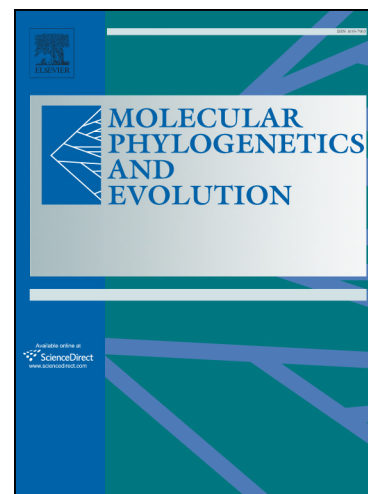

Title: Using a multi-gene approach to infer the complicated phylogeny and evolutionary history of lorises (Order Primates: Family Lorisidae).

Rachel A. Munds^{1,2}, Chelsea L. Titus³, Lori S. Eggert³, & Gregory E. Blomquist¹

¹Department of Anthropology, University of Missouri, Columbia, MO 65211

²Nocturnal Primate Research Group, Oxford Brookes University, Oxford OX3 0BP, UK

³Division of Biological Sciences, University of Missouri, Columbia, MO 65211

Corresponding Author:

Rachel A Munds

915 Danforth Dr.

Columbia, MO 65201

Email: rmunds27@gmail.com

Highlights

- A concatenated or complete taxa phylogeny reveal Lorisidae as monophyletic.
- Single-gene trees are inconsistent and result in polytomy with the outgroup *Galago*.
- The family Lorisidae is ancient with roots dating back ~40million years.

Abstract

Extensive phylogenetic studies have found robust phylogenies are modeled by using a multi-gene approach and sampling from the majority of the taxa of interest. Yet, molecular studies focused on the lorises, a cryptic primate family, have often relied on one gene, or just mitochondrial DNA, and many were unable to include all four genera in the analyses, resulting in inconclusive phylogenies. Past phylogenetic loris studies resulted in lorises being monophyletic, paraphyletic, or an unresolvable trichotomy with the closely related galagos. The purpose of our study is to improve our understanding of loris phylogeny and evolutionary history by using a multi-gene approach. We used the mitochondrial genes cytochrome *b*, and cytochrome *c* oxidase subunit 1, along with a nuclear intron (recombination activating gene 2) and nuclear exon (the melanocortin 1 receptor). Maximum Likelihood and Bayesian phylogenetic analyses were conducted based on data from each locus, as well as on the concatenated sequences. The robust, concatenated results found lorises to be a monophyletic family (Lorisidae) (PP \geq 0.99) with two distinct subfamilies: the African Perodictinae (PP \geq 0.99) and the Asian Lorisinae (PP \geq 0.99). Additionally, from these analyses all four genera were all recovered as monophyletic (PP \geq 0.99). Some of our single-gene analyses recovered monophyly,

but many had discordances, with some showing paraphyly or a deep-trichotomy. Bayesian partitioned analyses inferred the most recent common ancestors of lorises emerged $\sim 42 \pm 6$ million years ago (mya), the Asian Lorisinae separated $\sim 30 \pm 9$ mya, and Perodictinae arose $\sim 26 \pm 10$ mya. These times fit well with known historical tectonic shifts of the area, as well as with the sparse loris fossil record. Additionally, our results agree with previous multi-gene studies on Lorisidae which found lorises to be monophyletic and arising ~ 40 mya (Pereleman et al., 2011; Pozzi et al., 2014). By taking a multi-gene approach, we were able to recover a well-supported, monophyletic loris phylogeny and inferred the evolutionary history of this cryptic family.

Key words: Loris, monophyly, paraphyly, discordance, Miocene, Eocene, primates

1. Introduction

Inferring phylogenetic relatedness in deeply-diverged and cryptic organisms is a major challenge for biologists. Methods that rely on morphology to ascertain differences are useful but limited in scope as many cryptic species closely resemble each other (Bickford, 2007; Munds et al., 2013; Pozzi et al., 2015). Our understanding of cryptic species improved with the advent of genetics as many taxa were found to contain distinct genetic lineages. Early phylogenetic studies relied on single genes, often mitochondrial (mtDNA) genes, to analyze relationships (Lavergne et al., 1996; Porter et al., 1996; Rasmussen et al., 1998; Arnason et al., 1999), but more thorough research revealed dissonance in evolutionary rates among genes, emphasizing the need to use more than one gene and one type of gene for phylogenetic reconstructions (Springer et al., 2001; Rokas et al., 2003; Hedtke et al., 2006). What is known is that the incorporation of multiple genes from both the mitochondrial and nuclear genomes are helping researchers gain a clearer picture of the genetic relationships among cryptic species and their evolutionary histories, yet many taxa remain unexamined. Here, we adopt the use of multi-gene analyses to provide better insight to a primate family with an unresolved phylogeny, the lorises.

In addition, phylogenetic analyses are being improved by concatenating genes or through the use of a partitioned analysis which allows for the ideal model of molecular evolution for each individual locus (Springer et al., 2001; Rokas et al., 2003; Hedtke et al., 2006; Drummond et al., 2012). But studies have found that concatenation and partitioned analyses can be biased towards a single locus that overwhelms the phylogeny. Often these methods result in discordance between the designed gene-trees and the accepted species-tree (Pamilo & Nei, 1988; Kubatko, 2007; Heled & Drummond, 2009). To overcome for these incongruences, gene-tree species-tree analyses were developed. Unlike concatenation analyses that can be influenced strongly by one locus, the use of a multispecies coalescent or gene-tree species-tree reconciliation model has been demonstrated to provide a more robust phylogeny (Heled & Drummond, 2009; Larget et al., 2010; Pozzi et al., 2014). Specifically, reconciliation analyses do not average all gene trees together to create a species tree, but instead recognize the gene trees are rooted in the species tree and work back in time from the present to the past (whereas concatenation analyses work from the past to the present) (Heled & Drummond, 2009). Gene-tree species-tree reconciliation analyses are still new and not widely used, as concatenation and partitioned analyses still can produce well supported trees (Rokas et al., 2003; Heled & Drummond, 2009; Pozzi et al., 2014). To attempt to infer the most robust phylogeny for lorises we will employ both a partitioned analysis and a gene-tree species-tree reconciliation analysis. This type of methodology has been used on Lorisiformes (galagos and lorises) (Pozzi et al., 2014).

Galagos and lorises are the non-Malagasy radiation of strepsirrhine primates. There are five genera of galagos (family: Galagidae): *Galago*, *Galagoides*, *Euoticus*, *Otolemur*, and *Sciurocheirus*. All galagos are nocturnal, primarily vertical clingers and leapers or arboreal quadrupeds, omnivorous, and are only found in Africa (Nash et al., 1989; Bearder, 1999; Nekaris & Bearder, 2007; Pozzi et al., 2015; Svensson et al., 2016). Within lorises (family: Lorisidae) there are two genera in Africa (*Arctocebus* and *Perodicticus*) and two genera in Asia (*Loris* and *Nycticebus*). Lorises are nocturnal, omnivorous, arboreal quadrupeds that cannot leap (Nekaris & Bearder, 2007). All lorises share a suite of traits, such as cryptic locomotion in which they move steadily and quietly throughout the forest making them difficult to detect (Charles-Dominique, 1977; Nekaris & Bearder, 2007), and some are similarly built: robust (*Nycticebus* and *Perodicticus*) or gracile (*Loris* and *Arctocebus*). All lorises possess a strong grasp facilitated by a highly-extended hallux and pollex and a reduced second digit on their hands and feet (Rasmussen & Nekaris, 1998; Yoder et al., 2001; Harrison, 2010). This grasp can be kept tight for an extraordinarily long amount of time because of their unique circulation system (Harrison, 2010). Their crania are highly similar, with all genera having a diastema, and raised temporal lines. They also share specialized features in their post-crania, such as an elongated lumbar, a reduced tail, and practically equal lengths of their fore- and hind limbs (Cartmill, 1975; Schwartz & Tattersall, 1985; Masters et al., 2005). In general, this shared loris morphology is a common argument for their proposed monophyly.

It is widely accepted that galagos and lorises (African and Asian) comprise a monophyletic infraorder (Lorisiformes) distinct from the Malagasy lemurs (Pozzi et al., 2014;

Pozzi et al., 2015), but it is not as widely accepted that galago and loris families are monophyletic. Phylogenetic studies routinely distinguished the galagos, the African lorises, and the Asian lorises as three monophyletic groups, but the relationship among these groups remains a subject of debate due to differing interpretations of molecular, morphological, and biogeographic data (Yoder et al., 2001; Masters et al., 2005; Seiffert, 2007; Pozzi et al., 2014; Pozzi et al., 2015). A multi-gene approach clarified genus-level and species differences, and confirmed the monophyly of galagos (Pozzi et al., 2014; Pozzi et al., 2015). Such work has underscored the importance of using multiple genes for phylogenetic reconstruction, and the value of such research in interpreting the evolutionary histories of cryptic species. Although our understanding of galagos has improved, the same is not true for lorises. Much of the issue in interpreting loris phylogeny is due to a poor understanding of the relationship between the African and Asian lorises; without an improved understanding of their phylogeny we cannot adequately interpret their evolutionary history or dispersal events.

Currently, there are several commonly proposed phylogenies for the loris family, with the first being loris monophyly (Fig 1A; Schwartz & Tattersall, 1985; Roos et al., 2004; Harrison, 2010). It has also been suggested they are paraphyletic/diphyletic with an African loris-galago clade with an independent Asian loris group, or vice versa, an Asian loris-galago clade with the African lorises forming their own clade (Fig 1B; Yoder et al., 2000; Seiffert, 2003; Roos et al., 2004; Masters et al., 2005; Masters et al., 2007; Seiffert, 2007). Additionally, some propose all three primate groups (galagos, African lorises, and Asian lorises) are equally related to each other, forming an unresolvable trichotomy (Fig 1C; Pickford, 2012; Pozzi et al., 2015). In addition, there is debate on how the genera are related to each other. Commonly, it is accepted that there are African (subfamily Perodictinae: *Arctocebus*, and *Perodicticus*) and Asian (subfamily Lorisinae: *Loris* and *Nycticebus*) subfamilies (Rasmussen & Nekaris, 1998), but other topologies have been put forth. Based on morphology, it has been suggested that robust lorises (*Perodicticus* and *Nycticebus*), and gracile lorises (*Arctocebus* and *Loris*) form different groups (Schwartz & Tattersall, 1985). Karyotype studies have found *Nycticebus* and *Arctocebus* to be more closely related, with *Loris* and *Perodicticus* excluded (de Boer, 1973; Petter et al., 1979). Lastly, some have found *Perodicticus* to be an outgroup of the other lorises, based on cranial differences (Yoder, 1994). These various phylogenies are mainly based on morphological, fossil, and historical biogeographic analyses, although some have used molecular analyses too (de Boer, 1973; Petter et al., 1979; Yoder, 1994; Roos et al., 2004; Masters et al., 2007).

The geographic separation of the African (*Arctocebus* and *Perodicticus*) and Asian (*Loris* and *Nycticebus*) lorises, in which the African lorises share a continent with the closely-related galagos, suggest a complicated evolutionary history that is poorly represented in the fossil record. There are three, well-confirmed loris and galago fossils that have been discovered: the galagos *Saharagalago misrensis* and *Wadilemur elegans* and the loris *Karanisia*. All three are North African and have been dated to the Eocene (~35-41 million years ago (mya)) (Seiffert et al., 2005; Seiffert, 2007; Harrison, 2010; Seiffert, 2012). Additionally, there are three younger loris fossils dated to the Miocene (~6-10mya). From Pakistan, a partial skeleton was attributed

to *Nycticeboides simposoni*, and dental remains were attributed to *Microloris pilbeami* (Harrison, 2010). Finally, a 6mya snout from Kenya was attributed to a primate related to *Arctocebus* (Pickford, 2012). Based on the fossil record, some researchers have suggested that lorises have an Afro-Arabian origin (Roos et al., 2004; Masters et al., 2007; Seiffert, 2012; Pozzi et al., 2015). Others suggest that galagos evolved in Africa and lorises in Southeast (SE) Asia, and from there *Perodicticus* and *Arctocebus* spread to Africa during the late Miocene (Pickford, 2012). Such a proposal would explain why galagos are not present in SE Asia, but this proposal is not well supported by the Eocene fossil record (Seiffert, 2007; Seiffert, 2012).

Additionally, tectonic events inform our understanding of loris dispersal and evolution. During the Eocene (~40mya), a land bridge formed connecting Africa to Asia, and opening a possible route of dispersal to Asia. During this time, the Indian plate was moving away from Africa and towards Asia, which could have facilitated loris movement to Asia. The land bridge and movement of the Indian plate to Asia are estimated to have occurred from 29-55mya (Chatterjee & Scotese, 1999; Ali & Aitchison, 2008). This timeline matches well with galago-loris and African-Asian loris divergences, which are estimated to 40mya and 38 mya, respectively (Roos et al., 2005; Masters et al., 2007; Seiffert, 2007; Pozzi et al., 2015). Yet, it remains unclear as to the manner in which the African and Asian lorises split. Some have suggested lorises are exhibiting an amazing form of parallel evolution. This hypothesis is supported by past molecular studies that found lorises to be either paraphyletic or polyphyletic, even though morphologically they appear very similar. Through parallel evolution these cryptic primates could have evolved similar morphologies, even similar robust (*Perodicticus* and *Nycticebus*) and gracile (*Arctocebus* and *Loris*) morphs between the two African and Asian groups (Yoder et al., 2001; Masters et al., 2007). But, it is not unreasonable to propose that these primates are monophyletic, and that they rapidly evolved from each other after separating from galagos (~40mya), and before the African-Asian split (~38mya). In fact, a monophyletic family would be the most parsimonious explanation and is well supported by morphological and molecular-phenotype studies (Schwartz & Tattersall, 1985; Yoder et al., 2001; Roos et al., 2004; Pozzi et al., 2015). But without a resolved phylogeny, there is no way to infer their unique evolution, where they originated, and what traits would be considered ancestral or derived.

This study is one of the few studies to incorporate a multi-locus approach to infer the evolutionary history and relatedness within Lorisidae. There have been studies that have incorporated just a few mitochondrial DNA genes (mtDNA) or a few short interspersed nuclear elements (SINEs). Such research is important, but limited in scope, as mtDNA evolves faster than nuclear loci, and SINEs can be informative but incorporating different loci such as nuclear and mtDNA genes can provide a better understanding of the phylogenetic history of an organism. To date Pozzi et al., (2014) and Perelman et al., (2011) have provided the most detailed phylogenetic history of Lorisidae. Through the incorporation of 54 nuclear genes, Perelman et al., (2011) resolved a monophyletic Lorisidae family. Similarly, Pozzi et al., (2014) used 27 nuclear genes to recover a monophyletic Lorisidae phylogeny through maximum likelihood and Bayesian approaches, but gene tree species tree analyses found Galagidae to be

paraphyletic with Asian lorises to the exclusion of African lorises. Besides these two studies only Roos et al., (2004) found Lorisidae to be monophyletic based on molecular evidence. Unlike these previous studies, our research will use both mtDNA and nuclear DNA to resolve the Lorisidae phylogeny. In addition, we will incorporate multiple individuals from most genera to provide a more robust estimate of their evolutionary history.

It is clear that more work is needed to provide a well-resolved and reliably dated loris phylogeny. Our research was conducted to improve our understanding of the evolutionary history of the Lorisidae and will help assess the plausibility of proposed dispersal events and the amount of morphological homoplasy or stasis involved. We used two mitochondrial genes (cytochrome *b* (*cytb*) and cytochrome *c* oxidase subunit 1 (COI)) along with one intron of a nuclear (recombination activating gene 2 (*Rag2*)) and one exon of a nuclear gene (the melanocortin 1 receptor (*Mc1r*)). This study was focused only on interpreting the phylogenetic relationship of the lorises (not galagos), and the relationships among the loris genera. Furthermore, once phylogenies were established we inferred the divergence time of lorises, and the possible two subfamilies. This research will help determine the best scenarios of loris evolutionary history.

2. Methods

2.1 Samples

We obtained samples (DNA, hair, tissue) from captive specimens housed at AZA approved institutions (Table 1). The majority of our samples were hair follicles. Our collection protocol for hair follicles required little to no handling of the animal and adhered to humane animal handling guidelines (Animal Behavior, 2008). Keepers were instructed to wear sterile gloves and use a piece of tape to pluck hair and follicles from individual lorises. The tape was then wrapped over the ~20 hair follicles and stored in a clean, dry coin envelope. Each sample was stored separately in its own sterile envelope. Two *Nycticebus pygmaeus* samples were from deceased individuals from the Duke Lemur Center. Several of our samples were from the Frozen Zoo® Collection at the San Diego Institute for Conservation Research and were provided as extracted DNA. The use of captive individuals is not considered problematic as our research interests are assessing the phylogenetic relationship among, rather than within genera. Additionally, these species and genera are easily recognizable (Nekaris & Bearder, 2007) and

hybridization due to living together in zoos is unlikely. Beyond their phenotype, there are isolating mechanisms that would prevent hybridization, such as differences in chromosome numbers, with *Nycticebus* having $2n=50$ and *Arctocebus* having $2n=52$. Although *Perodicticus* and *Loris* have the same number of chromosomes ($2n=62$), they are phenotypically distinct from each other (deBoer, 1973; Chen et al., 1993).

We acknowledge that using captive individuals would be problematic if this study addressed within species diversity (Lacy, 1987; Bailey et al., 2007; Pastorini et al., 2015). Obtaining samples from wild populations can be costly, and most lorises are difficult to humanely capture (Wiens, 2002; Pozzi et al., 2015). While it is possible to use museum specimens, ancient DNA methods are time consuming, and can be costly (Mason et al., 2011). We found it most effective to use captive individuals, although doing so meant that we were unable to include *Arctocebus* in parts of our study, as there are none in captivity. Fortunately, past studies have sequenced some *Arctocebus* samples and made those sequences (Rag2 and *cytb*) available on GenBank, along with our outgroup sequences (Table 2).

Genomic DNA was extracted from hair follicles using the protocols of Eggert et al. (2005). For tissue samples, we extracted DNA using the DNeasy Blood and Tissue kit (Qiagen, Valencia, CA) with the manufacturer's protocols. For samples that were received as extracted DNA, we determined DNA concentrations using a Nano-drop spectrophotometer (Thermo Fisher Scientific, Waltham, M. A.) and diluted to a standard concentration (15 ng/ μ L) for amplification using the polymerase chain reaction (PCR).

2.2 Sequencing

We sequenced fragments of two mitochondrial and two nuclear loci respectively: cytochrome oxidase subunit 1 (COI), cytochrome *b* (*cytb*), and recombinant activation gene 2 intron (Rag2) and the melanocortin 1 receptor (Mc1r) (Table 3). Previous studies have sequenced *cytb* and Rag2 for most, if not all genera of lorises, and made those sequences publicly available on GenBank (Perelman et al., 2011; Pozzi et al., 2015). The use of COI was based on the Barcode of Life project, in which part of COI has been designated as the standard genetic locus for species identification (Hebert et al., 2003; Hajibabaei et al., 2007). This particular gene is considered quite good at discriminating closely related species, but it is not always reliable (Hebert et al., 2003; Waugh, 2007). The criteria for using Mc1r is based on some genera of lorises (*Loris* and *Nycticebus*) possessing vibrant face masks that have been used to distinguish species within the genus (Nekaris & Munds, 2010; Munds et al., 2013). The Mc1r is known to influence coat color in a variety of mammals suggesting that variation in this gene might be useful for demarcation in lorises (Hoekstra, 2006; Bradley & Mundy, 2008).

Amplifications were performed in 25 μL volumes containing 1X PCR Gold Buffer (50 mM KCL, 8 mM Tris-HCL), 0.2 mM dNTPs, 0.4 μM each forward and reverse primers, 2 mM MgCl_2 , 1X BSA, 0.5 U Amplitaq Gold DNA Polymerase (Thermo Fisher Scientific, Waltham, MA), and 1 μL (~ 15 ng) of DNA template. The PCR was performed under the following conditions: pre-denaturation at 95° for 10 minutes; 40 - 45 cycles of denaturation at 95°C for 1 minute, primer annealing at 55° - 60°C for 1 minute, and primer extension at 72° for 1 minute; and a final elongation step at 72°C for 10 minutes. Amplification products were visualized in a 2% agarose gel and prepared for sequencing with either a Qiaquick PCR Purification Kit (Qiagen, Valencia, CA) or an EXO-AP protocol. The QIAquick PCR Purification followed the standard protocol, except for incubation of the elution step for 5 minutes and elution in 20 μL of Buffer EB. Exo-AP Clean-up was run in 23.5 μL volume reactions containing 2.75 μL of 10x FastAP buffer (Thermo Fisher Scientific, Waltham, M. A.), 0.50 μL of 1 U/ μL FastAP (Thermo Fisher Scientific, Waltham, M. A.), 0.25 μL of 20 U/ μL Exonuclease I (New England Biolabs Inc., Ipswich, M. A.), and 20 μL of PCR product. The profile included incubation at 37°C for 30 minutes followed by enzyme inactivation at 80°C for 15 minutes. Purified PCR products were sequenced in both directions at the University of Missouri DNA Core Facility on a 3730x1 96-capillary DNA Analyzer with Applied Biosystems Big Dye Terminator cycle sequencing chemistry (Thermo Fisher Scientific, Waltham, M. A.).

2.3. Analyses

Forward and reverse sequences were aligned and edited using GENEIOUS software v. 8.0.5 (Biomatters, Ltd.). All sequences were tested for saturation effects using DAMBE (Xia, 2017). If there is saturation, particularly at the third codon, we would expect twice as many transversions as transitions in our sequences. Both our nuclear and mitochondrial genes had a higher number of transitions than transversions, indicating low saturation (Xia, 2017). Sequences were trimmed to remove primers and to uniform lengths and translated to test for the presence of pseudogenes (numts). Numts are quite common in mammals and even more so in primates. These mtDNA sequences in the nuclear genome are problematic, as they can provide unreliable, often slower, interpretations of evolution. We used universal primers to reduce the chance of amplifying numts, as well as by checking for numts after amplification (Thalman et al., 2004; Hazkani-Covo et al., 2010). For phylogenetic reconstruction, it is recommended to use outgroup species that are closely related, but not too closely related to the organisms of interest (Sanderson & Shaffer, 2002; Puslednik & Serb, 2008). Our interest was focused on the phyletic

relationships within the family of lorises, and therefore *Galago* and *Eulemur* were outgroups for the analyses. Outgroups *Eulemur* and *Galago*, and available *Arctocebus* sequences were added to alignments. *Eulemur* is a distant relative, but still in the same suborder (Strepsirrhines) as lorises. Galagos share the same infraorder with lorises (Lorisiformes), which makes them closely related, but it is commonly accepted they form their own family separate from lorises (Phillips & Walker, 2002; Nekaris & Bearder, 2007). Sequences were then aligned with outgroup and *Arctocebus* sequences and then trimmed. Basepair (bp) lengths and number of polymorphic sites for each gene were: 205bp and 58 polymorphic sites for COI, 331bp and 107 polymorphic sites for *cytb*, 716bp and 34 polymorphic sites for *Rag2*, and 731bp and 45 polymorphic sites for *Mc1r*.

We used Bayesian and ML analyses as both frameworks have known limitations, but by using both we can provide a robust model of loris phylogeny. Bayesian posterior probability (PP) results are sensitive to long branch lengths, as well as closely related taxa, and small sample sizes (Susko, 2008); our study is susceptible to all these factors. Yet, bootstrap probabilities (BP) from Maximum Likelihood (ML) analyses can be too conservative and result in a ML that may not properly reflect the topology (Douady et al., 2003; Susko et al., 2008). Theoretically, if our sample sizes are sufficient then our final tree results from both sets of analyses should be similar (Douady et al., 2003; Brooks et al., 2007; Susko et al., 2008). For Bayesian analyses, a sample size is considered sufficient when the ESS exceeds 200 (Susko, 2008; Drummond et al., 2012). For ML, running bootstraps more than 250 times is acceptable, but given our small sample size of individuals, we increased our bootstrap runs to 1000 (Douady et al., 2003; Susko et al., 2008).

In total, we analyzed eight datasets: each gene was analyzed separately and were titled by their gene name (COI, *cytb*, *Rag2*, and *Mc1r*). Additionally, there were two sets of *Rag2* and *cytb* analyses: one set that included *Arctocebus* and one set that did not include them. A Bayesian partitioned analysis was run on the combined mitochondrial genes (concatenated mtDNA), as well as all four genes that were analyzed (concatenated genes). Aligned sequences were uploaded to jModeltest ver. 2.1.7. The optimal model of nucleotide substitution was selected using the AICc criterion which is preferred with small datasets. An additional check was performed using the BIC criterion for our Bayesian analyses. Results from the BIC supported the nucleotide substitution model selected by the AICc. COI, *Rag2* and *Mc1r* were analyzed with the HKY model, whereas for *cytb* we used the GTR model. For the Bayesian analyses, concatenated analyses used each individual gene's substitution rate inferred from jModeltest. The ML analyses required determining the concatenated substitution model which was HKY for both analyses. Program MEGA7 was used for ML phylogenies (Kumar et al., 2015). Node supports less than 0.5 BP were discarded. A total of 1000 bootstrap replications were run for each Maximum Likelihood set of analyses performed.

A Bayesian approach was used to estimate phylogeny and divergence times using BEAST ver.2.4.5 (Drummond et al., 2012). Analyses incorporated the gene dataset generated from this research, as well as the two outgroup genera (*Eulemur* and *Galago*) and *Arctocebus* when available.

A total of eight Bayesian analyses were run (Rag2 with and without *Arctocebus*, COI, *cytb* with and without *Arctocebus*, Mc1r, concatenated mtDNA, and concatenated genes). Based on our results from jModeltest we implemented a GTR+G substitution model for *cytb* with the shape parameter of the gamma distribution fixed to 0.295. An HKY substitution model was used for COI with kappa set to 21.4686. The substitution model for Rag2 was an HKY+I with proportion of invariable sites fixed to 0.681 and a kappa of 4.8769. An HKY+G substitution model was used for Mc1r, with a gamma shape parameter of 0.1970 and a kappa set to 10.2679. The concatenated models used Bayesian partitioned analyses so that each locus used the ideal model of molecular evolution in the analysis. All analyses used an uncorrelated lognormal relaxed-clock (ucl) model. There was variation on some of the priors for each gene due to the difference in models. For all models, we used a Yule process of speciation on the tree prior, with birth rate as a gamma distribution ($\alpha=0.001$, $\beta=1000$) for *cytb* and all the genes, and a uniform distribution for the remainder of the analyses. Gamma shape was exponential with a mean of 1. Both the ucl mean and ucl standard deviation varied depending on the genes being analyzed. Two calibration points with normal distributions were used to obtain the estimated divergence times of the Lorisidae genera. A mean of 58 mya, with a standard deviation of 3.0 was used for the time to most recent common ancestor (TMRCA) for Lemuriformes and Lorisiformes. The TMRCA for galagos and lorises was 40 mya with a standard deviation of 3.0. The dates used are based on well-supported fossil dates and other phylogenetic studies (Yoder et al., 2001; Seiffert, 2007; Harrison, 2010; Perlelemann et al., 2010; Pickford 2012).

Four independent Markov chain Monte Carlo (MCMC) runs were used for each set of analyses. Each run was 40 million generations with an initial 50000 burn-in and sampled every 1000 for both log and tree files. Log files were imported into Tracer ver 1.4.1, where we checked to make sure the estimated sample size (ESS) was sufficient. Our sampling was more than enough as all ESSs exceeded 200 (most exceeded 1000) and trace plots all appeared as expected. TreeAnnotater ver. 2.4.5 was used to prepare each tree file for examination. Parameters for TreeAnnotater files were: 25% burn-in, target tree type was Maximum clade credibility, and node heights were established by mean heights. Each tree file was independently inspected before combining all tree files for each set of analyses with LogCombiner ver. 1.5.3. Final combined trees were viewed in FigTree ver. 1.3.1. Consensus trees detailing the Bayesian Posterior Probability (PP) and ML Bootstrap Probability (BP) from analyses were designed using TreeGraph2 (Stover & Muller, 2010), unless there were major discrepancies between analyses. Minimum displayed node support for Bayesian was 75%.

In addition to Bayesian and ML analyses, we ran a Bayesian framework for a species-tree multispecies coalescent using *BEAST (Heled & Drummond, 2009). Our primary purpose for this analysis was to account for uncertainty in the individual gene trees. Often results from

concatenated gene trees can be heavily influenced by a single gene, and instead of accurately depicting a species tree they end up showing a gene-tree. The multi-species coalescent circumnavigates this problem by allowing each gene tree to influence each other (Heled & Drummond, 2009; Liu & Edwards, 2009; Pozzi et al., 2014).

We used *BEAST a template within BEAST ver. 2.4.5 (Drummond et al., 2012) to run our multispecies coalescent species tree. All four loci (*cytb*, COI, Rag2, and Mc1r) were used for these analyses, as well as all individual Lorisidae analyzed in the study. Parameters for each locus were maintained from the above partitioned Bayesian analyses. Substitution models and tree models were independent for each locus, but the clock model for COI and *cytb* were not separated, as they are both mtDNA and expected to share similar clock rates (Heled & Drummond, 2009; Drummond et al., 2012). All individual lorises were kept in the model, but *Arctocebus* was excluded as we did not have this genus for all genes analyzed. We used a Yule model for the species tree and a gamma distribution for the birthrate. Our model was run for 400 million generations, with an initial burn-in of 500 thousand, and we stored every 4000 generations for log and tree files. Log files were imported into Tracer ver. 1.4.1, where we checked to make sure the ESS was sufficient. All parameters exceeded the minimum ESS threshold of 200. TreeAnnotater ver. 2.4.5 was used to prepare the tree file for examination. Parameters used were 10% burn in, with 0.5 posterior probability, target tree was Maximum clade credibility and node heights were established at the median heights. A total of 90001 trees were viewed in FigTree ver. 1.3.1, with minimum node support set to 50%.

3. Results

3.1. Phylogeny

Based on our concatenated genes analyses (Fig 2; Fig Supplementary(S).1) and our complete taxa analyses (Rag2 and *cytb*) (Fig 3) we found lorises to be monophyletic ($PP \geq 0.99$, $BP \geq 0.89$) and with one distinct subfamily, the Asian lorises (Lorisinae) ($PP \geq 0.99$, $BP \geq 0.93$) (Fig 2). We could not confirm an African subfamily (Perodictinae) from the concatenated analyses as *Arctocebus* was not included in the analyses. But based on our Rag2 (Fig 3A; Fig S.6A) and *cytb* (Fig 3B; Fig 3A) analyses that included *Arctocebus*, Perodictinae was significantly supported ($PP \geq 0.99$, $BP \geq 0.97$). From all three (concatenated, Rag2 with *Arctocebus*, and *cytb* with *Arctocebus*) analyses, all genera were well-supported and distinct.

Our concatenated mtDNA tree and single gene trees were inconsistent with the concatenated and complete taxa topologies (Fig. 4). Only Mc1r results support loris monophyly ($PP \geq 0.99$, $BP \geq 0.91$) with an Asian loris subfamily ($PP \geq 0.99$, $BP \geq 0.91$) (Fig. 4A; Fig S.5). But Mc1r ML and Bayesian results differed, as ML supported a galago-*Perodicticus* clade. Mc1r

was the only gene tree to fail in resolving species within *Nycticebus*, intermingling *N. coucang* and *N. pygmaeus*. Most of our single gene trees have polytomies, with no clear resolution to the loris phylogeny. The weak BP and PP results of COI (Fig 4B; Fig S.4) suggest that *Galago*, *Perodicticus*, *Loris*, and *Nycticebus* are all equally related. Each genus is well-supported, but based on Bayesian analyses, *N. coucang* does not form its own species group (PP \geq 0.46, BP \geq 0.85). Similarly, the concatenated mtDNA (Fig 4C; Fig S.2) analyses resulted in a polytomy among *Galago* and the loris genera, but *N. coucang* remained a distinct species (PP \geq 0.99, BP \geq 0.99). Finally, the exclusion of *Arctocebus* from *cytb* and *Rag2* analyses failed to recover loris monophyly. *Cytb* without *Arctocebus* resulted in loris polytomy. *Rag2* without *Arctocebus* (Fig 4D; Fig S.6B) found lorises to be paraphyletic, as it had weak support for a monophyletic loris family (PP \geq 0.36, BP \geq 0.72), thus pushing back the *Perodicticus* branch and making them equally related to galagos as they are to the distinct Asian loris subfamily (PP \geq 0.99, BP \geq 0.94).

Our discordances between the results of our single-gene and mtDNA analyses prompted us to run a multispecies coalescent model. Results regarding the relationships among the five genera analyzed were different from our concatenated analyses. There was weak support for loris monophyly (PP \geq 0.48). Instead, we found *Perodicticus* to be equally related to galagos as they are to the Asian lorises (PP \geq 0.99) (Fig. 5).

3.2. Evolutionary History

Based on our concatenated gene results we found the loris family's (Lorisidae) most recent common ancestor (MRCA) emerged roughly 42mya. Even though we are cautious of our single gene results, we are confident of our concatenated gene analysis because all our results (single and combined gene analyses) indicated the MRCA of Lorisidae was present within the 95% confidence intervals (CI) of the concatenated gene's results (36-47mya), with a minimum age of 38mya (*Rag2* without *Arctocebus*) and a maximum of 42mya (concatenated genes). Lorisinae was dated to 30mya (CI: 22-39mya), with *Loris* having a relatively young emergence of 4mya (0.5-9mya) and an older *Nycticebus* date of 18mya (10-27mya). Once again, results from other analyses that had a Lorisinae subfamily fell within the 95% CI of our concatenated results, with *Rag2* without *Arctocebus* being on the lower cusp at 23my and *cytb* having the oldest estimated age at 34my. Similarly, results for *Loris* were comparable too, except COI and mtDNA dated the genus as much older (12 and 13my, respectively). *Nycticebus* results fell within the concatenated genes CI range, with COI and mtDNA results skirting the upper CI range (25.5 and 26my, respectively). As previously stated, we were only able to acquire

Arctocebus sequences for *cytb* and *Rag2*, therefore Perodictinae age inferences were based on those results. Based on both analyses we estimated the MRCA of Perodictinae emerged 26mya (CI: 13-38mya). We only had multiple sequences of *Arctocebus* with our *cytb* analyses, which resulted in an estimated age of 6mya (CI: 1-11.43mya). Based on concatenated genes *Perodicticus* was younger than the other genera, with its MRCA dated to 3.5my (CI:0.4-8). Yet, COI, *Rag2* with *Arctocebus*, and mtDNA all found the MRCA of *Perodicticus* to be older (14.5, 8.2, 16my, respectively). Finally, we were able to determine the emergence of *N. coucang* and *N. pygmaeus*. It is estimated *N. coucang* arose 7 mya (CI: 2-12.5mya) and *N. pygmaeus* is dated to 5mya (CI: 0.94-10.27mya). Once again, COI and mtDNA analyses found these species to be relatively older, with *N. coucang* dated to 17my, and *N. pygmaeus* dated to 15my (COI) or 17my (mtDNA). Even though there is variation among our results, the majority of our results fall within the 95% CI of the concatenated genes, adding further support to our conclusions.

4. Discussion

4.1. *Loris Phylogeny*

By using multiple genes from both the mitochondrial and nuclear genomes we found lorises to be an ancient, monophyletic group (Lorisidae) with African and Asian lorises as distinct monophyletic subclades (Perodictinae and Lorisinae, respectively). Moreover, results from all analyses found each recognized loris genus to be monophyletic (Table 4). Prior confusion surrounding loris phylogeny resulted from immunological, karyotype, and genetics studies that relied on a single gene, often a mitochondrial gene. These past molecular studies were limited in scope or excluded some of the genera in the analyses. Additionally, many of these molecular studies failed to agree with the extensive studies on morphology that found a monophyletic Lorisidae (Rasmussen & Nekaris, 1998; Yoder et al., 2001; Masters et al., 2005). As previously stated, the four Lorisidae genera share numerous traits that unite them as a family, such as a reduced index finger, a unique vascular system that enhances their ability to grasp, cryptic locomotion, extended hallux and pollex, a diastema, as well as many more features (Rasmussen & Nekaris, 1998; Harrison, 2010), which are unlikely to have evolved in parallel. Like the morphology studies that incorporated a variety of analyses to conclude monophyly, and a few molecular studies that also resolved a monophyletic Lorisidae, our research demonstrates the importance of multiple genes from both the nuclear and mitochondrial genomes to interpret family relationships (Kullnig-Gradinger et al., 2002; Hedtke et al., 2006; Perelmann et al., 2011; Pozzi et al., 2014).

We have discordance between our results based on concatenated sequences and those based on single genes, and our multispecies coalescence gene-tree species-tree model, which highlights the challenges researchers have faced in trying to interpret a molecular loris phylogeny. Although our concatenated and complete-taxa analyses resulted in a monophyletic Lorisidae with two distinct subfamilies (Fig. 2 & 3), many of our single-gene analyses and the coalescence analysis resulted in either loris paraphyly (Fig. 4D, Fig. 5), or a polytomy of equally related groups among *Galago*, *Perodicticus*, *Loris*, and *Nycticebus* group (Fig 4 A, B, & C).

These varying results are unsurprising, as past Lorisidae phylogenies built using a single gene or only mtDNA have similar conclusions. Both Porter et al., (1997) and Yoder et al., (2001) noted Lorisinae to be more closely related to galagos than to Perodictinae. These results were based solely on genetic analyses that used one or two genes, mainly mtDNA; a monophyletic Lorisidae was recovered when morphology was also included in the analyses (Yoder et al., 2001). Masters et al., (2005) had similar incongruences with their own study, as they could not recover a monophyletic Lorisidae with their genetic results based on 12S, 16S, and a combined 12S and 16S rRNA gene analysis. Instead they found Lorisidae to be paraphyletic with Lorisinae linked to galagos, like past studies (Porter et al., 1997; Yoder et al., 2001), or with Perodictinae as a sister taxon to galago, similar to our results from Rag2 that excluded *Arctocebus*. Yet, Masters et al., (2005) recovered a monophyletic Lorisidae when they excluded *Microcebus* as their outgroup, and instead used galagos.

As for the different results based on analysis methods, Pozzi et al., (2014) also ran a gene-tree species-tree analysis to infer the relationships among galagos and lorises. Similar to our results, they found Lorisinae to be monophyletic, but they could not conclude Lorisidae monophyly. Instead, their results found Lorisinae and galagos to form a sister relationship to the exclusion of Perodictinae (Pozzi et al., 2014). Although our results were not in complete agreement with their findings, we both found Lorisidae was not monophyletic with gene-tree species-tree coalescence analyses. Unlike Pozzi et al., (2014), we found Perodictinae to form a sister-taxa with galago. This could be a result of missing taxa, as we were unable to include *Arctocebus* in these analyses. No other studies have done such analyses on Lorisidae phylogeny, so although we find this approach useful, we will base our conclusions of Lorisidae phylogeny on the Bayesian partitioned analyses.

Pozzi et al., (2014; 2015) has provided the most recent, and possibly most comprehensive investigation into Lorisidae phylogeny. Their 2015 analyses used one gene for their interpretation (*cytb*). While *cytb* is a well-conserved gene and has been used by many to recover phylogenies (Zardoya & Meyer, 1996) studies have found that it is not always reliable (Springer et al., 2001). Using *cytb*, Pozzi et al., (2015) could not confirm the monophyly of Lorisidae, and instead found it to be paraphyletic, with Perodictinae more related to galagos than to Lorisinae. Roos et al. (2004) also used whole *cytb* sequences, as well as sequences from two strepsirrhine-specific short interspersed nuclear elements (SINEs). Similarly, their *cytb* results did not confirm a monophyletic Lorisidae, and instead showed a deep trichotomy between the galagos, the Asian, and the African lorises (Roos et al., 2004). Our own *cytb* results provide weak support for monophyly, particularly when *Arctocebus* is not included in the analyses; in this case we find Lorisidae to form a trichotomy with the galagos, Asian, and African lorises. Yet, based on three SINE loci, Roos et al., (2004) support monophyly with three integrations, and further support a common ancestor for Perodictinae and Lorisinae. Pereleman et al. (2011) examined loris phylogeny in the context of examining the whole Primates Order. Unlike most past studies, they used multiple introns and exons of nuclear genes for phylogenetic reconstruction, providing a more robust interpretation, but they had a small number of samples from each genus, often only

one individual. Pozzi et al., (2014) used 27 nuclear genes to specifically determine the evolutionary history of Galagidae, but also incorporated Lorisidae to provide a more detailed history. Both their ML and Bayesian analyses found Lorisidae to be monophyletic, but the coalescent results determined them to be paraphyletic with Asian lorises more closely related to Galagidae than to the African lorises. Like Roos et al. (2004), and our concatenated results, Perelemann et al., (2011) found Lorisidae to be monophyletic (ML 71-80%). The monophyly of Lorisidae is well-supported when multiple nuclear genes are considered, but not when the analysis is based on single genes, particularly mitochondrial genes (Roos et al., 2004; Perleman et al., 2011).

The use of multiple genes, and different types of genes to recover a robust phylogeny is not a new concept, but this method has rarely been used for phylogenetic analyses with the Lorisidae. Although, some have proposed that at least 20 genes should be used for phylogenetic analyses (Rokas et al., 2003), others have demonstrated that as few as three genes can suffice as long as taxon sampling is sufficient (Hedtke et al., 2006; Heath et al., 2008). Robust phylogenies are inferred by using a variety of genes, and not just mitochondrial genes (Kullnig-Gradinger et al., 2002; Hedtke et al., 2006). Additionally, complete or near-complete taxon sampling improves phylogenetic accuracy (Pollock et al., 2002; Zwickl & Hillis, 2002; Hillis et al., 2003). This was demonstrated quite well with our own study, as the only monophyletic single-gene trees were from those that include all the Lorisidae genera (Fig. 3), and *Mc1r*. Cytochrome *b* with *Arctocebus* is a polytomy within Lorisidae, but *Galago* is not a part of that polytomy, unlike the other single-gene trees in which *Galago* is part of the polytomy. By using a variety of genes, and sampling from all the taxa, researchers can avoid common pitfalls, such as nuclear mitochondrial pseudogenes (Numts), high measures of repeatability, and errors in alignment and interpretation of insertions and deletions (Sorenson & Quinn, 1998; Bensasson et al., 2001; Zwickl & Hillis, 2002; Heath et al., 2008; Loytynoja & Goldman, 2008; Song et al., 2008; Fletcher & Yang, 2010). Similarly, our study circumvents these issues as we used four genes, both mitochondrial and nuclear, sampled from all the genera, and used more than one individual to represent each genus. By incorporating all these methods, we have a well-supported loris phylogeny.

4.2. Evolutionary History

Based on our analyses, and other evolutionary studies, we estimate Lorisidae emerged during the Eocene around 41 mya (HPD 95%: 36-47.1mya) (Perelemann et al., 2011; Pozzi et al., 2015). Once Lorisidae split from galagos (Galagidae), we predict a subfamily division occurred, resulting in Lorisinae and Perodictinae arising during the Oligocene (~30mya). Because we do not have *Arctocebus* sequences for all analyses we can only confidently provide Perodictinae divergence estimates from *Rag2* and *cytb* (26 mya and 27 mya, respectively). Alternatively, we were able to acquire sequences from all the genes of interest for *Loris* and *Nycticebus* to provide a robust Lorisinae estimate. On average, Lorisinae's most recent common

ancestor (MRCA) is dated to 29mya, with an early divergence of 36.5mya (*cytb* without *Arctocebus*) and the youngest dating to 22.6mya (Rag2 without *Arctocebus*). Similarly, Perelmann et al., (2011) and Pozzi et al., (2014; 2015) found deep divergences between the Lorisidae subfamilies with Lorisinae emerging ~29mya and Perodictinae ~23mya. Such a deep divergence, roughly 30mya of independent evolution, implies that Lorisidae diversified rapidly, resulting in two distinct morphologies for each subfamily: robust (*Perodicticus* and *Nycticebus*) and gracile (*Arctocebus* and *Loris*). Our study reaffirms the extraordinarily deep-divergences within Lorisidae, emphasizing the complicated evolutionary history these primates present in comparison to other primates (Perelman et al., 2011).

Some researchers have suggested that Lorisidae arose in Asia and then moved to Africa (Masters et al., 2005), with some adding that from the African group galagos emerged (Pickford, 2012). This suggestion would provide an easy explanation as to the absence of galagos from Asia, but it is not in agreement with the current fossil record or our concatenated results. Our concatenated results suggest that Lorisidae arose ~41mya and are monophyletic. This is in accordance with the dating of *Karanisia* which is dated to 35-51mya and found in Egypt (Seiffert, et al., 2005; Seiffert, 2007; Harrison, 2010; Seiffert, 2012). A North African point of origin is in contradiction to the loris Asian origin proposal, but a North African dispersal of Lorisidae is supported by well-accepted biogeographic changes—although it does not explain why galagos are not present in Asia. Their absence on Asia could have been due to competition with tarsiers (*Tarsius*), another vertical-clinging, small-bodied primate, that shares a similar diet with galagos. It could also be attributed to a lack of resources, or the tectonic shifts that aided Lorisidae dispersal was not favorable to galagos (Fleagle, 2013). Biogeographically, it is understood that India began to separate from Seychelles and Gondwana around 65mya but remained intermittently connected to North Africa for around 20my afterwards, thus remaining connected to this region until about 45mya (de Wit, 2003; Ali & Aitchison, 2008), and then eventually it collided with Tibet ~35mya (Ali & Aitchison, 2008). The 35mya collision of India to Tibet correlates to our MRCA of Lorisinae which is dated to 22.6-36.5mya. It also supports the over 30my of separation between Lorisinae and Perodictinae. From our analyses, not only is a monophyletic Lorisidae supported, but our dates are corroborated from well-documented geographic and fossil dates.

We are confident with our genus-level results as they are comparable to past molecular studies, but the species and possible genus level differences that Pozzi et al., (2015) suggested between *N. coucang* and *N. pygmaeus* are tentatively proposed as we have insignificant posterior support for *N. coucang* when using Rag2 and COI. Like other studies, *Nycticebus* is the oldest genus with its MRCA dated to 12.9-26.7mya, or 18.4mya based on results when using the concatenated genes. The species divergence within this genus are quite deep too, with the MRCA for *N. coucang* at 6.49 and *N. pygmaeus* at 4.87 mya. This seemingly long-term separation between species has caused some to propose that *N. pygmaeus* should be its own genus (Pozzi et al., 2015), as few primate species exhibit such distinct morphological difference and millions of years of separation from each other (Goodman et al., 1998; Yoder & Yang, 2000;

Perelmann et al., 2011; Fleagle, 2013). In general, our results support Pozzi et al. (2015), who claim that *N. pygmaeus* should be its own genus but given our weak support for phylogenetic distinction based on some of the genes, we suggest more analyses be done. In comparison to *Nycticebus*, the other Lorisidae genera are relatively younger with *Loris* emerging 4.08 mya and *Perodicticus* at only 3.53 mya. We are not reporting *Arctocebus* results, as they are only based on one gene (*cytb*). The relatively young MRCA dates for these latter two genera, in comparison to *Nycticebus*, could be used to further support the genus level distinction of *N. pygmaeus*.

The evolutionary history of Lorisidae is difficult to interpret, as our understanding is based on a handful of fossils, and a reasonable comprehension of the biogeographic history. The dearth of fossils is a major hindrance in interpreting their evolution. There are three well-supported Lorisiformes fossils (*Saharagalago*, *Wadilemur*, and *Karanisia*) from North Africa that are dated to the Eocene (35-41mya) (Seiffert et al., 2005; Seiffert, 2007; Harrison, 2010; Seiffert, 2012). After these fossils, there is an almost 35my gap before the next dated fossils. Of three Miocene (6-10mya) fossils, two are from Pakistan for the possible ancestral Lorisinae, and one is from Kenya for the ancient *Arctocebus* (Harrison, 2010; Pickford, 2012). The Eocene and Miocene fossil dates are what are used when calibrating Bayesian analyses to infer Lorisidae evolution (Masters et al., 2007; Perelman et al., 2011; Pozzi et al., 2015), and could possibly be contributing to the difficulty of interpreting them. Ideally, more fossils will be found that are dated between the Eocene and Miocene, which will provide a better idea of Lorisidae evolution, but at this time researchers must rely on other methods, such as molecular analyses to understand Lorisidae. By combining the fossil evidence with what we know of the biogeographic history of North Africa and Asia, we can provide a reasonable reconstruction of Lorisinae's dispersal to Asia.

5. Conclusion

Our research emphasizes the importance of incorporating several genes, of varying types, for phylogenetic reconstruction, and the importance of sampling from all members of the taxa (Rokas et al., 2003; Hedtke et al., 2006). Research on other ancient (40my+) taxa have demonstrated a single gene tree is not reflective of a species tree, with single gene trees producing different phylogenetic reconstructions and inconsistencies. By using a variety of genes misinterpretation can be avoided (Hedtke et al., 2006). We provide one of the most comprehensive loris molecular phylogenies by using several types of genes and sampling from all members of the taxa. Our results found lorises to be a monophyletic family, Lorisidae, with two subfamilies: the Asian Lorisinae and the African Perodictinae. The distinctiveness of these subfamilies has elicited suggestions that they be up-listed to family status (Pozzi et al., 2015), and future research should investigate that proposal. We anticipate increases in the genetic data and sample sizes may reveal significant separation between the two subfamilies. Additionally, future work should examine the possible genus level separation of *N. pygmaeus* from *N. coucang*, as our concatenated results support such a division along with Pozzi et al., (2015).

The evolutionary history of Lorisidae is mired because of the lack of fossils, and the difficulty in interpreting the dispersal of these primates from North Africa to Asia. Until more

fossils are unearthed, we can only speculate when and how they arrived in Asia, and why galagos are not present in Asia. What our study demonstrates is that Lorisidae has a deep-evolutionary history, emerging during the Eocene roughly 40mya. From there the two subfamilies quickly diverged around the Oligocene/Miocene, with each subfamily retaining similar gracile and robust forms. An improved understanding of Lorisidae evolution will only be found with more molecular studies that incorporate a multitude of sequences, a larger taxa set (Rokas et al., 2003; Hedtke et al., 2006), and of course more fossils.

Acknowledgements

We thank the American Zoological Association for their assistance with this project, and the participatory zoos and institutions. Dr. Helena Fitch-Snyder for her advice, information on the AZA captive lorises, and her time. Drs Elena Less and Mike Dulaney for studbook information. Finally, we thank financial support from Sigma Xi. Also, we thank two anonymous reviewers who greatly improved the quality of this manuscript.

Works Cited

Ali, JR., Aitchison, J.C., 2008. Gondwana to Asia: Plate tectonics, paleogeography and the biological connectivity of the Indian sub-continent from the Middle Jurassic through latest Eocene (166-35Ma). *Earth-Sci. Rev.* 88(3): 145-166.

Animal Behavioral Society. 2008. Guidelines for the treatment of animals in behavioral research and teaching. *Animal Behavior Society Handbook*.

Arnason, U., Gullberg, A., Janke, A., 1999. The mitochondrial DNA molecule of the aardvark, *Orycteropus afer*, and the position of the Tubulidentata in the eutherian tree. *Proc. R. Soc. Lond. B. Biol. Sci.* 266: 339-345.

Bailey, N.W., Macias Garcia, C., Ritchie, M.G., 2007. Beyond the point of no return? A comparison of genetic diversity in captive and wild populations of two nearly extinct species of Goodeid fish reveals that one is inbred in the wild. *Heredity* 98: 360-367.

Barsh, G.S., 1996. The genetics of pigmentation: from fancy genes to complex traits. *Trends in Genetics* 12(8):299-305.

Bearder, S.K., 1999. Physical and social diversity among nocturnal primates: a new view based on long term research. *Primates* 40(1): 267-282.

Bensasson, D., Zhang, D., Hartl, D.L., Hewitt, G.M., 2001. Mitochondrial pseudogenes: evolution's misplaced witnesses. *TRENDS Ecol. Evolut.* 16(6): 314-321.

Bickford, D., Lohman, D.J., Sodhi, N.S., Ng, P.K.L., Meier, R., Winker, K., Ingram, K.K., Das, I., 2006. Cryptic species as a window on diversity and conservation. *TRENDS Ecol. Evolut.* 22(3):148-155.

Bradley, B.J., Mundy, N.I., 2008. The primate palette: The evolution of primate coloration. *Evol. Anthr.* 17:97-111.

Cartmill, M., 1975. Strepsirhine basicranial structures and the affinities of the Cheirogaleidae. In: *Phylogeny of the Primates*. USA: Spring Press, 313-354.

Charles-Dominique, P., 1977. *Ecology and behavior of nocturnal primates: prosimians of equatorial West Africa*. New York: Columbia University Press, 1977.

Chatterjee, S., Scotese, C.R., 1999. The breakup of Gondwana and the evolution and biogeography of the Indian plate. *Proc.-Indian Natl. Sci. Acad. Part A.* 65(3): 397-426.

Chen, Z., Zhang, Y., Shi, L., Liu, R., Wang, Y., 1993. Studies on the chromosomes of genus *Nycticebus*. *Primates* 34(1): 47-53.

de Boer, L.E.M., 1973. Cytotaxonomy of the Lorisioidea (Primates: Prosimii). *Genetica* 44(3): 330-367.

de Wit, M.J., 2003. Madagascar: Heads it's a continent, tails it's an island. *Annu. Rev. Earth Planet. Sci.* 31(1): 213-248.

Douday, C.J., Delsuc, F., Boucher, Y., Doolittle, W.F., Douzery, E.J., 2003. Comparison of Bayesian and maximum likelihood bootstrap measures of phylogenetic reliability. *Mol. Biol. Evol.* 20(2): 248-254.

Drummond, A.J., Suchard, M.A., Xie, D., Rambaut, A., 2012. Bayesian phylogenetics with BEAUti and the BEAST 1.7. *Mol. Biol. Evol.* 29(8):1969-1973

Eggert, L.S., Maldonado, J.E., Fleischer, R.C., 2005. Nucleic acid isolation from ecological samples: animal scat and other associated materials. *Mol. Evol.: Producing the Biochemical Data, Part B. Methods in Enzymol.* 6: 73-80.

Fleagle, J.G., *Primate Adaptation and Evolution*. New York, Academic Press.

- Fletcher, W., Yang, Z., 2010. The effect of insertions, deletions, and alignment errors on the branch-site test of positive selection. *Mol. Biol. Evol.* 27(10): 2257-2267.
- Goodman, M., Porter, C.A., Czeulsnia, J., Page, S.L., Schneider, H., Shoshani, J., Gunnell, G., Groves, C.P., 1998. Toward a phylogenetic classification of primates based on DNA evidence complemented by fossil evidence. *Mol. Phylogenet. Evol.* 9(3): 585-598.
- Groves, C.P., 1971. Systematics of the genus *Nycticebus*. In: Biegert J, Leutenegger W, editors. Taxonomy, anatomy, reproduction. Proc. of the 3rd Intl. Congress of Primatol. 1:44-53.
- Hajibabaei, M., Singer, G.A., Hebert, P.D., Hickey, D.A., 2007. DNA barcoding: how it complements taxonomy, molecular phylogenetics and population genetics. *TRENDS Genet.* 23(4): 167-172.
- Harrison, T., 2010. Later tertiary Loriformes. In: Werdelin L, Sanders W (eds). *Cenozoic mammals of Africa*. Berkely: University of California Press, 333-349.
- Hazkani-Covo, E., Zeller, R.M., Martin, W., 2010. Molecular poltergeists: Mitochondrial DNA copies (numts) in sequenced nuclear genomes. *PLoS Genetics.* 6(2): 1-11.
- Heath, T.A., Hedtke, S.M., Hillis, D.M., 2008. Taxon sampling and the accuracy of phylogenetic analyses. *J. Syst. Evol.* 46(3): 239-257.
- Hebert, P.D.N., Cywinska, A., Ball, S.L., 2003. Biological identifications through DNA barcodes. *Proc. R. Soc. Lond. B. Biol. Sci.* 270(1512): 313-321.
- Hedtke, S.M., Townsend, T.M., Hillis, D.M., 2006. Resolution of phylogenetic conflict in large data sets by increased taxon sampling. *Syst. Biol.* 55(3): 522-529.
- Heled, J., Drummond, A.J., 2009. Bayesian inference of species trees from multilocus data. *Mol. Biol. Evol.* 27(3): 570-580.
- Hillis, D.M., Pollock, D.D., McGuire, J.A., Zwickl, D.J., 2003. Is sparse taxon sampling a problem for phylogenetic inference? *Syst. Biol.* 52(1): 124-126.
- Hoekstra, H.E., 2006. Genetics, development and evolution of adaptive pigmentation in vertebrates. *Heredity.* 97(3): 222
- Kubatko, L.S., 2007. Inconsistency of phylogenetic estimates from concatenated data under coalescence. *Syst. Biol.* 56(1): 17-24.
- Kullnig-Gradinger, C.M., Szakacs, G., Kubicek, C.P., 2002. Phylogeny and evolution of the genus *Trichoderma*: a multigene approach. *Mycological Research.* 106(7): 757-767.
- Lacy, R.C., 1987. Loss of genetic diversity from managed populations: Interacting effects of drift, mutation, immigration, selection, and population subdivision. *Conserv. Biol.* 1(2): 143-158.

- Larget, B.R., Kotha, S.K., Dewey, C.N., Ane, C., 2010. BUCKy: Gene tree/ species tree reconciliation with Bayesian concordance analysis. *Bioinfo.* 26(22): 2910-2911.
- Lavergne, A., Douzery, E., Stichler, T., Catzeflis, F.M., Springer, M.S., 1996. Interordinal mammalian relationships: evidence for paenungulate monophyly is provided by complete mitochondrial 12S rRNA sequences. *Mol. Phylogenet. Evol.* 6: 245-258.
- Liu, L., Edwards, S.V., 2009. Phylogenetic analysis in the anomaly zone. *Syst. Biol.* 58(41): 452-460.
- Loytynoja, A., Goldman, N., 2008. Phylogeny-aware gap placement prevents errors in sequence alignment and evolutionary analysis. *Science* 320: 1632-1635.
- Mason, V.C., Li, G., Helgen, K.M., Murphy, W.J., 2011. Efficient cross-species capture hybridization and next-generation sequencing of mitochondrial genomes from noninvasively sampled museum specimens. *Genome Res.* 21(10): 1695-1704.
- Masters, J.C., Anthony, N.M., De Wit, M.J., Mitchell, A., 2005. Reconstructing the evolutionary history of the Lorisidae using morphological, molecular, and geological data. *Am. J. Phys. Anthropol.* 127(4):465-480.
- Masters, J.C., Boniotto, M., Crovela, S., Roos, C., Pozzi, L., Delpero, M., 2007. Phylogenetic relationships among the Lorisidae as indicated by craniodental morphology and mitochondrial sequence data. *Am. J. Primatol.* 69:6-15.
- Munds, R.A., Nekaris, K.A.I., Ford, S.M., Taxonomy of the Bornean loris with new species *Nycticebus kayan* (Primates, Lorisidae). *Am. J. Primatol.* 75(1):46-56.
- Nash, L., Bearder, S., Olson, T., 1989. Synopsis of galago species characteristics. *Int. J. Primatol.* 10: 57-80.
- Nekaris, K.A.I., Bearder, S.K., 2007. The Lorisiform primates of Asia and mainland Africa: Diversity shrouded in darkness. In: Campbell C, Fuentes A, MacKinnon K, Panger M, Bearder SK (eds) *Primates in Perspective*. Oxford University Press, Oxford, UK p 24-45
- Nekaris, K.A.I., Munds, R., 2010. Using facial markings to unmask diversity: The slow lorises (Primates: Lorisidae: *Nycticebus*) of Indonesia. In: Gursky S, Supriatna J, editors. *The Primates of Indonesia* New York: Springer p 383-396.
- Pamilo, P., Nei, M., 1988. Relationships between gene trees and species trees. *Mol. Biol. Evol.* 54(5): 568-583.
- Pastorini, J., Sauter, M.L., Sussman, B.W., Gould, L., Cuzzo, F.P., Fernando, P., Nievergelt, C.M., Mundy, N.I., 2015. Comparison of the genetic variation of captive ring-tailed lemurs with a wild population in Madagascar. *Zoo Biol.* 34: 463-472.

- Perelmann, P., Johnson, W.E., Roos, C., Seuanez, H.N., Horvath, J.E., Moreira, M.A.M., Kessing, B., Pontius, J., Roelke, M., Rumpler, Y., Schneider, M.P.C., Silva, A., O'Brien, S.J., Pecon-Slattery, J., 2011. A molecular phylogeny of living primates. *PLoS Genet.* 7(3):1-17.
- Petter, J.J., Petter Rousseaux, A., 1979. Classification of the prosimians. In: Doyle, G.A., Martin, R., (eds) *The Study of Prosimian Behavior*. Academic Press, New York p 1-44.
- Phillips, E.M., Walker, A., 2002. Fossil lorisooids. In: Hartwig, W.C., editor. *The Primate Fossil Record*. Cambridge, Cambridge University Press p 83-95.
- Pickford, M., 2012. Lorisine primate from the Late Miocene of Kenya. *J. Biologic. Res.- Bollentino della Societa Italiana di Biologia Sperimentale* 85(1).
- Pollock, D.D., Zwickl, D.J., McGuire, J.A., Hillis, D.M., 2002. Increased taxon sampling is advantageous for phylogenetic inference. *Syst. Biol.* 51(4): 664-671.
- Porter, C.A., Goodman, M., Stanhope, M.J., 1996. Evidence on mammalian phylogeny from sequences of exon 28 of the von Willebrand factor gene. *Mol. Phylogenet. Evol.* 5: 89-101.
- Pozzi, L., Disotell, T.R., Masters, J.C., 2014. A multilocus phylogeny reveals deep lineages within African galagids (Primates: Galagidae). *BMC Evol. Biol.* 14:72.
- Pozzi, L., Nekaris, K.A.I., Perkin, A., Bearder, S.K., Pimley, E.R., Schulze, H., Streicher, U., Nadler, T., Kitchener, A., Zischler, H., Zinner, D., Roos, C., 2015. Remarkable ancient divergences amongst neglected lorisoiform primates. *Zool. J. Linnean Soc.* 175: 661-674.
- Puslednik, L., Serb, J.M., 2008. Molecular phylogenetics of the Pectinidae (Mollusca: Bivalvia) and effects of increased taxon sampling and outgroup selection on tree topology. *Mol. Phylogenet. Evol.* 48: 1178-1188.
- Rasmussen, A., Janke, A., Arnason, U., 1998. The mitochondrial DNA molecule of the hagfish (*Myxine glutinosa*) and vertebrate phylogeny. *J. Mol. Evol.* 46: 382-388.
- Rasmussen, D.T., Nekaris, K.A.I., 1998. Evolutionary history of lorisoiform primates. *Folia Primatol.* 69(Suppl. 1):250-285.
- Rokas, A., Williams, B.L., King, N., Carroll, S.B., 2003. Genome-scale approaches to resolving incongruence in molecular phylogenies. *Nature.* 425(6960): 798.
- Roos, C., Schmitz, J., Zischler, H., 2004. Primate jumping genes elucidate strepsirrhine phylogeny. *Proc. Natl. Acad. Sci. USA.* 101:10650-10654.
- Sanderson, M.J., Shaffer, H.B., 2002. Troubleshooting molecular phylogenetic analyses. *Annu. Rev. Ecol. Evol.* 33:49-72.

- Schwartz, J.H., & Tattersall, I., 1985. Evolutionary relationships of living lemurs and lorises (Mammalia, Primates) and their potential affinities with European Adapidae. *Anthropological Papers of the American Museum of Natural History*. 60:1-100.
- Seiffert, E.R., Simons, E.L., Attia, Y., 2003. Fossil evidence for an ancient divergence of lorises and galagos. *Nature*. 422: 421-424.
- Seiffert, E.R., 2007. Early evolution and biogeography of lorisiform strepsirrhines. *Am. J. Primatol.* 69: 27-35.
- Seiffert, E.R., 2012. Early primate evolution in Afro-Arabia. *Evol. Anthropol.* 21(6): 239-253.
- Song, H., Buhay, J.E., Whiting, M.F., Crandall, K.A., 2008. Many species in one: DNA barcoding overestimates the number of species when nuclear mitochondrial pseudogenes are coamplified. *Proc. Natl. Acad. Sci.* 105(36): 13486-13491.
- Sorenson, M.D., Quinn, T.W., 1998. Numts: A challenge for Avian systematics and population biology. *The Auk*. 115(1): 214-221.
- Springer, M.S., DeBry, R.W., Douday, C., Amrine, H.M., Madsen, O., de Jong, W.W., Stanhope, M.J., 2001. Mitochondrial versus nuclear gene sequences in deep-level mammalian phylogeny reconstruction. *Mol. Biol. Evol.* 18(2): 132-143.
- Stover, B.C., Muller, K.F. 2010. TreeGraph 2: Combining and visualizing evidence from different phylogenetic analyses. *BMC BioInfo.* 11(7): 1-9.
- Susko, E., 2008. On the distributions of bootstrap support and posterior distributions for a star tree. *Syst. Biol.* 57(4):602-612.
- Svensson, M.S., Bersacola, E., Mills, M.S.L., Munds, R.A., Nijman, V., Perkin, A., Masters, J.C., Couette, S., Nekaris, K.A.I., Bearder, S.K., 2017. A giant among dwarfs: a new species of galago (Primates: Galagidae) from Angola. *Am. J. Phys. Anthropol.* 163(1): 30-43.
- Thalmann, O., Hebler, J., Poinar, H.N., Paabo, S., Vigilant, L., 2004. Unreliable mtDNA data due to nuclear insertions: a cautionary tale from analysis of humans and other great apes. *Mol. Ecol.* 13: 321-335.
- Waugh, J., 2007. DNA barcoding in animal species: Progress, potential and pitfalls. *BioEssays* 29(2): 188-197.
- Wiens, F., 2002. Behavior and ecology of wild slow lorises (*Nycticebus coucang*): Social organization, infant care system, and diet. Doctoral Dissertation University of Bayreuth.
- Xia, X., 2017. DAMBE6: New tools for microbial genomics, phylogenetics and molecular evolution. *J. Heredity.* 108(4): 431-437.

Yoder, A.D., 1994. Relative position of the Cheirogaleidae in strepsirrhine phylogeny: A comparison of morphological and molecular methods and results. *Am. J. Phys. Anthropol.* 94(1): 25-46.

Yoder, A.D., Rasoloarison, R.M., Goodman, S.M., Irwin, J.A., Atsalis, S., Ravosa, M.J., Ganzhorn, J.U., 2000. Remarkable species diversity in Malagasy mouse lemurs (Primates, *Microcebus*). *Proc. Natl. Acad. Sci.* 97(21):11325-11330.

Yoder, A.D., Yang, Z., 2000. Estimation of primate speciation dates using local molecular clocks. *Mol. Biol. Evol.* 17(7): 1081-1090.

Yoder, A.D., Irwin, J.A., Payseur, B.A., 2001. Failure of the ILD to determine data combinability for slow loris phylogeny. *Syst. Biol.* 50(3): 408-424.

Zardoya, R., Meyer, A., 1996. Phylogenetic performance of mitochondrial protein-coding genes in resolving relationships among vertebrates. *Mol. Biol. Evol.* 13: 933-942.

Zwickl, D.J., Hillis, D.M., 2002. Increased taxon sampling greatly reduces phylogenetic error. *Syst. Biol.* 51(4): 588-598.

Tables

Table 1: Loris samples acquire for this study from American Zoological Association institutions

Table 2: GenBank sequences incorporated within the study

Table 3: Primer sequences from this study

Table 4: Node support (posterior probability (PP) & bootstrap probability (BP), Divergence times in million years (MY), Divergence 95% highest posterior density (HPD), rate & rate 95%HPD, and branch lengths (Bayesian posterior probability (PP) and Maximum likelihood (ML)) results from all analyses.

Table 1: Loris samples acquired for this study from American Zoological Association institutions

Genus/Species	Identification	Specimen Facility	Sample Type
<i>Nycticebus coucang</i>	SD734	San Diego Zoo	DNA
	SD 283	San Diego Zoo	DNA
	SD303	San Diego Zoo	DNA
	SD435	San Diego Zoo	DNA
	SD302	San Diego Zoo	DNA
	MZ9750	Minnesota Zoo	Hair
	MZ9585	Minnesota Zoo	Hair
<i>Nycticebus pygmaeus</i>	DLC001	Duke Lemur Center	Tissue
	DLC002	Duke Lemur Center	Tissue
	CZM1	Capron Park Zoo	Hair
	SD299	San Diego Zoo	DNA
	CZSC1	Chicago Zoological Society	Hair
	ABQP1	ABQ Biopark	Hair
	CZBGC1	Cincinnati Zoo & Botanical Garden	Hair
	<i>Loris</i>	SD699	San Diego Zoo
SD138		San Diego Zoo	DNA
SD698		San Diego Zoo	DNA

	SD203	San Diego Zoo	DNA
<i>Perodicticus</i>	CZBGH1	Cincinnati Zoo & Botanical Garden	Hair
	CZBGM1	Cincinnati Zoo & Botanical Garden	Hair
	CZBGG1	Cincinnati Zoo & Botanical Garden	Hair
	CZBGJ1	Cincinnati Zoo & Botanical Garden	Hair
	CZBGI1	Cincinnati Zoo & Botanical Garden	Hair
	CMPT1	Cleveland Metroparks Zoo	Hair

Table 2: GenBank sequences incorporated within the study

Genus	GenBank accession number	Genetic sequence
<i>Arctocebus</i>	HM759000.1	Rag2
	KP410672.1	Cytb
	KP410667.1	Cytb
	KP410665.1	Cytb
	KP410621.1	Cytb
<i>Galago moholi</i>	HM759002.1	Rag2
	KJ543730.1	COI
	AY441470.1	Cytb
<i>Galago senegalensis</i>	AY205138.1	Mclr
<i>Eulemur macaco</i>	HM758988.1	Rag2
	JF444301.1	COI
	AF081050.1	Cytb
<i>Eulemur fulvus</i>	AY205141.1	Mclr

Table 3, separate document

ACCEPTED MANUSCRIPT

Table 4: Node support (posterior probability (PP) & bootstrap probability (BP), Divergence times in million years (MY), Divergence 95% highest posterior density (HPD), rate & rate 95%HPD, and branch lengths (Bayesian posterior probability (PP) and Maximum likelihood (ML)) results from all analyses.

Locus	Taxon	Node Support (PP/BP)	Date (MY)	Date 95% HPD	Rate	Rate 95% HPD	Branch Length (PP/ML)
All Genes	Lorisidae	0.99/0.89	41.65	36.02-47.11	0.001	0-0.001	14.81/0.007
	<i>Perodicticus</i>	1/1	3.53	0.42-8.11	0.002	0.001-0.002	38.12/0.052
	Lorisinae	1/0.93	30.3	21.92-38.79	0.002	0.001-0.004	11.35/0.019
	<i>Loris</i>	1/0.99	4.08	0.46-9.21	0.002	0.001-0.003	26.22/0.033
	<i>Nycticebus</i>	1/1	18.4	10.244-26.95	0.002	0.001-0.004	11.9/0.022
	<i>N. coucang</i>	1/0.99	6.49	1.76-11.68	0.002	0.001-0.004	11.9/0.02
	<i>N. pygmaeus</i>	1/0.99	4.87	0.95-9.61	0.002	0.001-0.003	13.52/0.017
Cytb	Lorisidae	0.99/0.82	41.11	35.65-46.52	0.0045	0.0003-0.0101	15.8/0.036
Arctocebus	Perodictinae	0.9/0.67	26.87	15.78-38.14	0.0045	0.0002-0.0107	14.24/0.048
	<i>Arctocebus</i>	1/0.99	5.53	1.0023-11.43	0.0094	0.0037-0.0161	21.34/0.159
	<i>Perodicticus</i>	1/1	4.55	0.71-9.87	0.0063	0.0019-0.0119	22.32/0.114
	Lorisinae	0.63/0.35	33.85	23.93-42.79	0.0028	0.0001-0.0074	7.25/0.021

	<i>Loris</i>	1/0.99	3.97	0.24-9.68	0.0032	0.0009-0.006	29.89/0.072
	<i>Nycticebus</i>	0.99/0.81	21.98	12.49-31.71	0.0074	0.0018-0.0143	11.87/0.079
	<i>N. coucang</i>	1/0.99	6.8	2.0-12.47	0.0087	0.0028-0.0155	15.18/0.105
	<i>N. pygmaeus</i>	1/0.97	5.08	0.94-10.27	0.005	0.0009-0.0105	16.9/0.081
Cytb*	Lorisiformes	0.99/.82	41.25	35.36-46.82	0.0035	0.0001-0.0124	15.47/0.028
	Galago split	0.34/NA	28.45	15.77-41.14	0.0026	0.0001-0.0076	6.21/
	<i>Perodicticus</i>	1/1	4.21	0.59-9.22	0.0092	0.0032-0.0163	30.84/0.150
	Lorisinae	0.33/0.55	30.88	19.47-41.97	0.0039	0.0001-0.0109	4.75/0.033
	<i>Loris</i>	1/0.99	3.62	0.21-8.76	0.0045	0.0011-0.0091	32.88/0.072
	<i>Nycticebus</i>	0.99/0.80	21.97	11.33-33.49	0.0079	0.001-0.0163	14.42/0.076
	<i>N. coucang</i>	1/0.99	6.3	1.71-11.82	0.01	0.0031-0.0181	15.79/0.105
	<i>N. pygmaeus</i>	1/0.99	4.79	0.91-10.01	0.0057	0.008-0.021	17.29/0.08
COI*	Lorisiformes	0.98/	40.82	35.14-46.6	0.0085	0-0.0385	16.01/NA
	<i>Loris/Africa</i>	0.33/0.48	31.44	17.95-43.15	0.0051	0-0.0263	9.38/0.139
	Galago split	0.37/0.28	23.53	9.04-38.35	0.0108	0-0.0487	7.91/0.120
	<i>Perodicticus</i>	0.93/0.99	14.54	2.8-28.52	0.0367	0-0.1104	8.99/0.471
	<i>Loris</i>	0.99/0.99	11.79	0.75-25.88	0.0392	0.0023-0.1187	19.65/0.594
	<i>Nycticebus</i>	0.81/0.95	25.53	12.91-38.28	0.0337	0-0.0977	15.29/0.051
	<i>N. coucang</i>	0.46/0.95	17.19	1.7-25.31	0.004	0-0.0205	8.34/0.351
	<i>N. pygmaeus</i>	0.89/0.97	14.59	4.17-26.05	0.0251	0-0.0747	10.94/0.167
Rag2*	Lorisidae	0.99/0.97	41.68	36.07-47.3	0.0002	0-0.0005	14.44/0.013
Arctocebus	Perodictinae	0.99/0.97	26.01	13.45-38.24	0.0004	0.0001-0.0007	15.67/0.006
	<i>Perodicticus</i>	0.98/0.94	8.17	1.5-17.21	0.0003	0-0.0007	17.83/0.005
	Lorisinae	1/0.97	25.32	15.01-36.14	0.0005	0.0001-0.0012	16.36/0.01
	<i>Loris</i>	1/0.98	7.09	1.09-15.73	0.0005	0.0001-0.0009	18.23/0.01
	<i>Nycticebus</i>	0.99/0.87	14.46	6.03-24.93	0.0004	0-0.0008	10.86/0.004
	<i>N. coucang</i>	0.39/0.97	10.49	3.58-19.37	0.0003	0-0.0005	3.97/0.004
	<i>N. pygmaeus</i>	0.99/0.87	6.91	1.72-14.01	0.0004	0-0.0008	7.55/0.003
Rag2	Lorisidae	0.36/0.72	38.18	25.48-43.43	0.0003	0-0.0006	1.84/0.002
	<i>Perodicticus</i>	1/0.99	7.78	1.15-17.9	0.0004	0.0001-0.0008	30.4/0.011
	Lorisinae	0.99/0.94	22.69	12.5-33.91	0.0006	0-0.0012	15.49/0.010
	<i>Loris</i>	1/0.99	6.42	0.9-14.68	0.0005	0.0001-0.001	16.28/0.009
	<i>Nycticebus</i>	0.99/0.98	12.91	4.79-22.94	0.0004	0-0.0009	9.79/0.004
	<i>N. coucang</i>	0.39/0.98	11.52	2.65-17.57	0.0003	0-0.0006	1.39/0.001
	<i>N. pygmaeus</i>	0.99/0.87	6.12	1.4-12.88	0.0004	0-0.0009	6.79/0.003
mtDNA*	Lorisiformes	0.96/NA	40.54	34.84-46.39	0.0165	0-0.573	16.02/NA
	<i>Loris/Africa</i>	0.33/0.63	30.02	15.13-42.52	0.0036	0-0.0128	10.51/0.021
	Galago split	0.33/NA	23.61	8.72-39.27	0.0041	0-0.0114	6.41/NA
	<i>Perodicticus</i>	1/1	16.39	3.49-31.42	0.0672	0.0043-0.1843	7.22/0.153
	<i>Loris</i>	0.99/1	13.46	1.18-28.78	0.052	0.0025-0.1584	16.57/0.111
	<i>Nycticebus</i>	0.99/0.99	26.41	13.13-39.66	0.064	0-0.1976	14.12/0.086
	<i>N. coucang</i>	0.99/0.99	16.97	5.04-30.27	0.0482	0-0.1577	9.45/0.072
	<i>N. pygmaeus</i>	0.89/1	17.28	5.09-30.57	0.0266	0-0.0716	9.13/0.071
Mclr*	Lorisidae	0.99/0.91	40.87	35.16-46.58	0.0003	0-0.0007	16.01/0.04
	<i>Perodicticus</i>	1/0.99	7.99	1.43-16.78	0.0009	0.0004-0.0015	32.87/0.024
	Lorisinae	0.99/0.91	25.67	14.9-36.73	0.0008	0.0001-0.0017	15.19/0.013
	<i>Loris</i>	1/0.94	8.19	1.31-16.86	0.0005	0.0001-0.0011	17.49/0.009
	<i>Nycticebus</i>	0.99/0.93	13.94	5.91-23.11	0.0006	0.0001-0.0014	11.73/0.007

*Maximum likelihood results differ from Bayesian results.

Figure Legend:

Figure 1: Commonly proposed loris phylogenies

Figure 2: Monophyletic Lorisidae phylogeny based on concatenated genes

Figure 3: Lorisidae phylogenies from Rag2 and cytochrome *b*.

Figure 4: Lorisidae phylogenies from Mc1r, COI, mtDNA, and Rag2 without *Arctocebus*

Figure 5: Coalescent-based species tree analyses on 900001 trees from *Beast. All four loci were used for this analysis, as well as all lorises excluding *Arctocebus*.

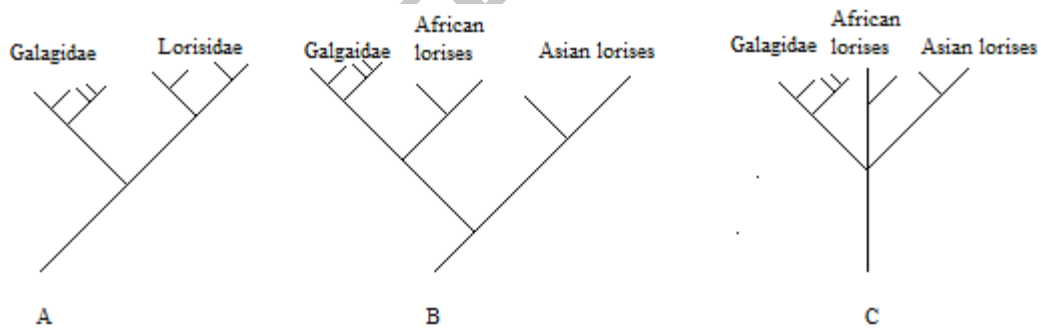

Figure 1: Commonly proposed loris phylogenies: (A) shows a monophyletic loris (Lorisidae) grouping, (B) shows a geographically parsimonious African and Asian grouping (a less parsimonious alternative is Asian lorises are more closely related to galagos-not shown), (C) indicates that Galagidae, the African, and the Asian lorises are all equally related.

ACCEPTED MANUSCRIPT

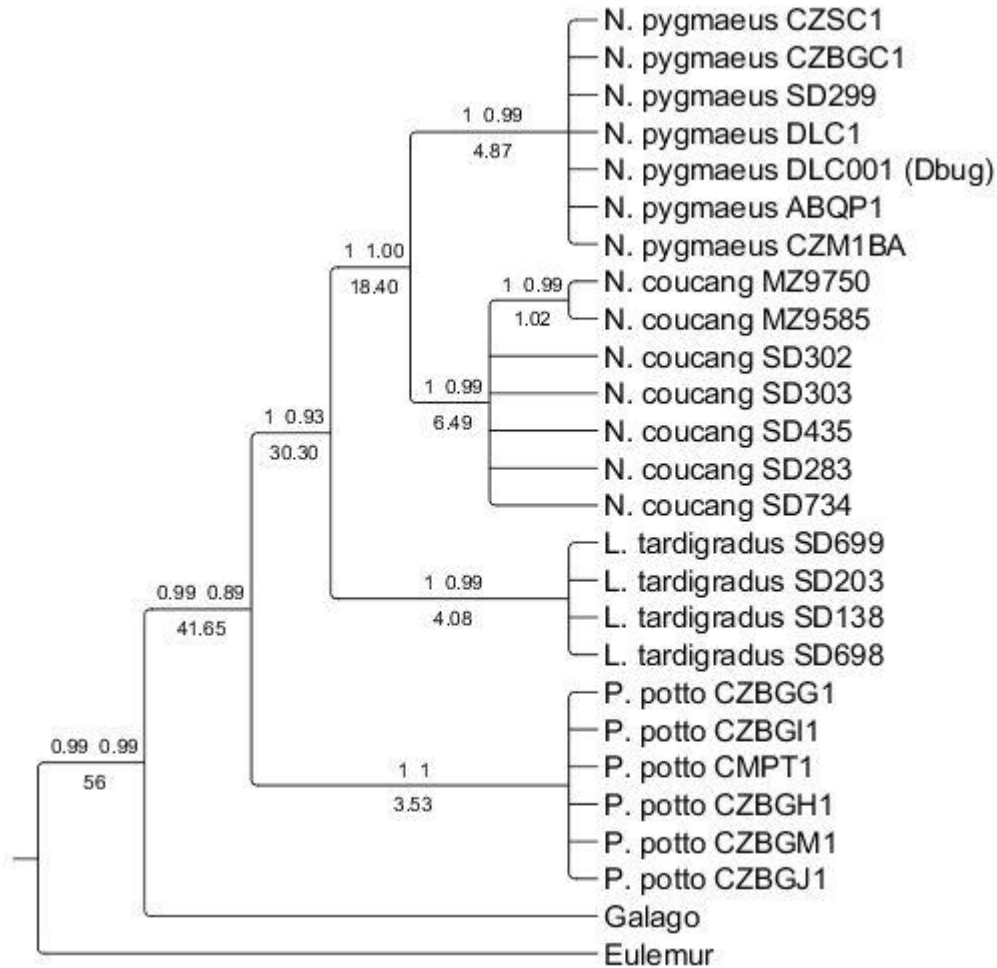

Figure 2: Monophyletic Lorisidae phylogeny based on concatenated genes. Numbers below branches are the divergence date in million years of the node. Numbers on top of the branches to the left are the Bayesian posterior probability, and numbers to the right are the Maximum Likelihood bootstrap probability for the node.

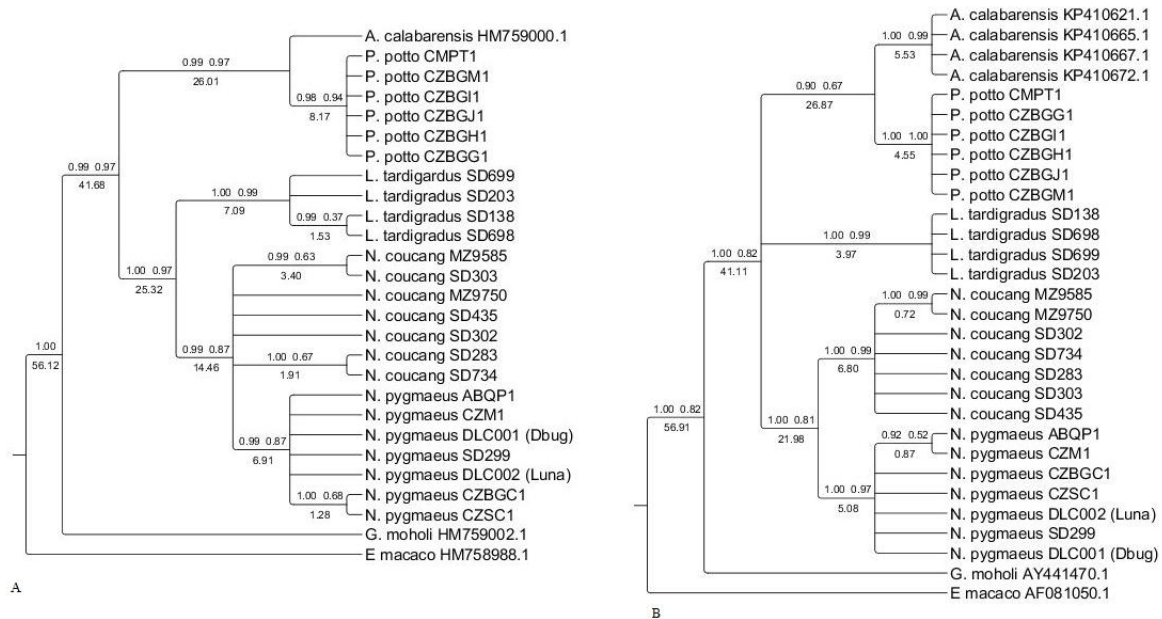

Figure 3: Lorisidae phylogenies from Rag2 (A) and cytochrome b (B) with *Arctocebus* sequences. Support values on branches are the same as Figure 1.

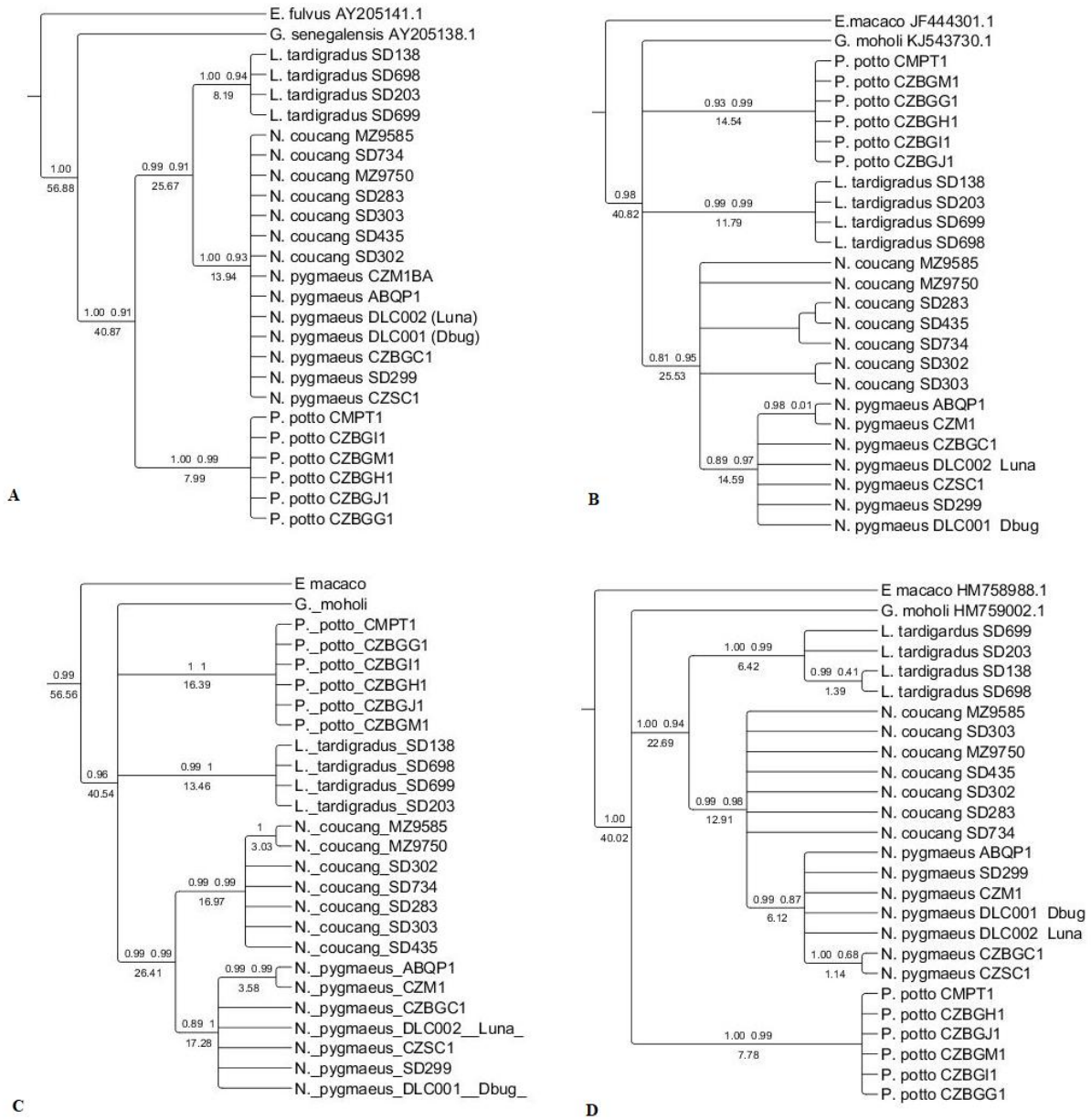

Figure 4: Lorisidae phylogenies from Mc1r (A), COI (B), concatenated mtDNA (C), and Rag2 without *Arctocebus* (D). Support values on branches are the same as Figure 1.

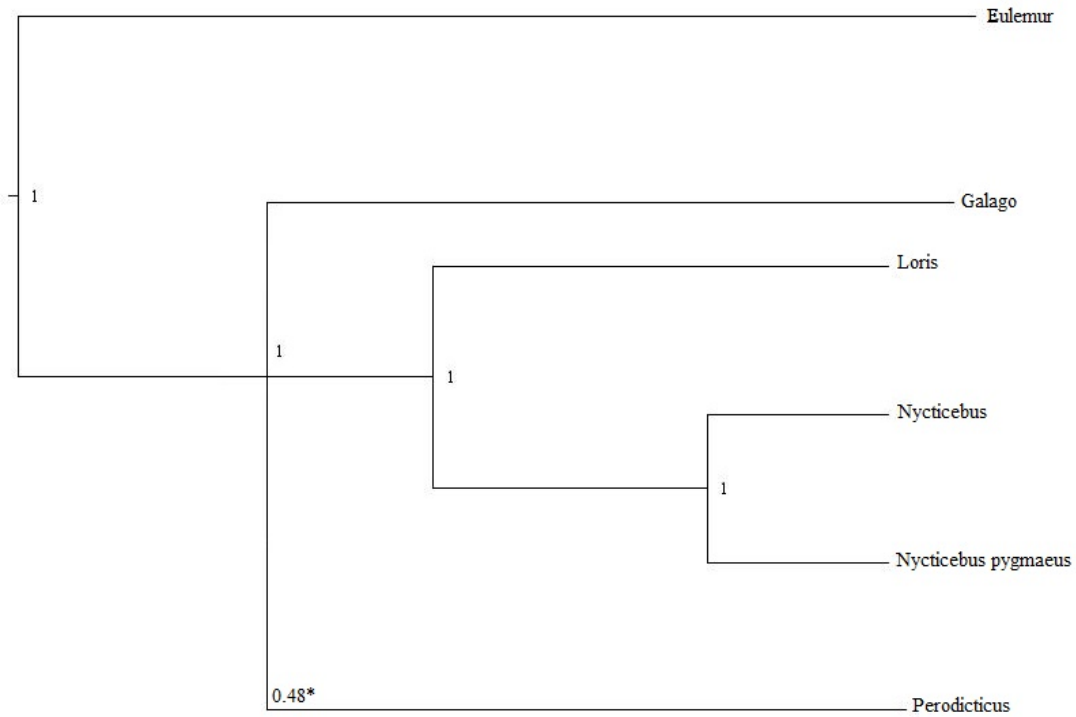

Figure 5: Coalescent-based species tree analyses on 900001 trees from *Beast. All four loci were used for this analysis, as well as all lorises excluding *Arctocebus*. Nodes show posterior probability. The 48% probability linked to *Perodicticus* indicates the weak support for Lorisidae monophyly.

Table 3: Primer sequences from this study

Locus/ Basepairs used	Primer Sets (5'-3')		Reverse		Annealing Temp (°C)	Source
	Forward					
COI 205	5477F	AAG TTT GCT AAT CCG AGC AGA G	5740R	ATG AGG CTA GGA GAA GAA GGA	55°	5
	LtarCO12F	AAT TAG GCC AGCC CAG GGA CT	LtarCO12R	AAG AAT CAG AAT AGA TGT TGA TAG AGG	55°	1
Cyt. <i>b</i> 331	CB1	CCA TCC AAC ATC TCA GCA TGA TGA AA	CB2	CCC TCA GAA TGA TAT TTG TCC TCA	55°	2
RAG2 716	RAG2F	GAT TCC TGC TAY CTY CCT CCT CT	RAG2R	CCC ATG TTG CTT CCA AAC CAT A	55°	4
	RAG2F	GAT TCC TGC TAY CTY CCT CCT CT	RAG2R2	GAT AGC CCA TCC TGA AGT TCT	55°	2 & 4
	RAG2F2	GTG GAT TTT GAA TTT GGG TGT	RAG2R	CCC ATG TTG CTT CCA AAC CAT A	55°	2 & 4
MC1R 731	MC1R-F	AGT GCC TGG AGG TGT CTG T	MC1R-R1	GCA CCT CCT TGA GTG TCT TG	60°	1
	MC1R-F	AGT GCC TGG AGG TGT CTG T	MC1R-R1.1	AAT GAA GAG GGT GCT GGA GA	58°	1 & 2
	MC1R-F.2	ATA TCA CAG CAT CGT GAC TCT	MC1R-R1	GCA CCT CCT TGA GTG TCT TG	55°	1 & 2

Designed by Munds using Primer3 (Rozen & Skaletsky, 1998)

²Kocher et al. (1989)

³Palumbi et al. (1991)

⁴Perelman et al. (2011)

⁵Mary Blair, Ph.D. (personal communication)

Graphical abstract

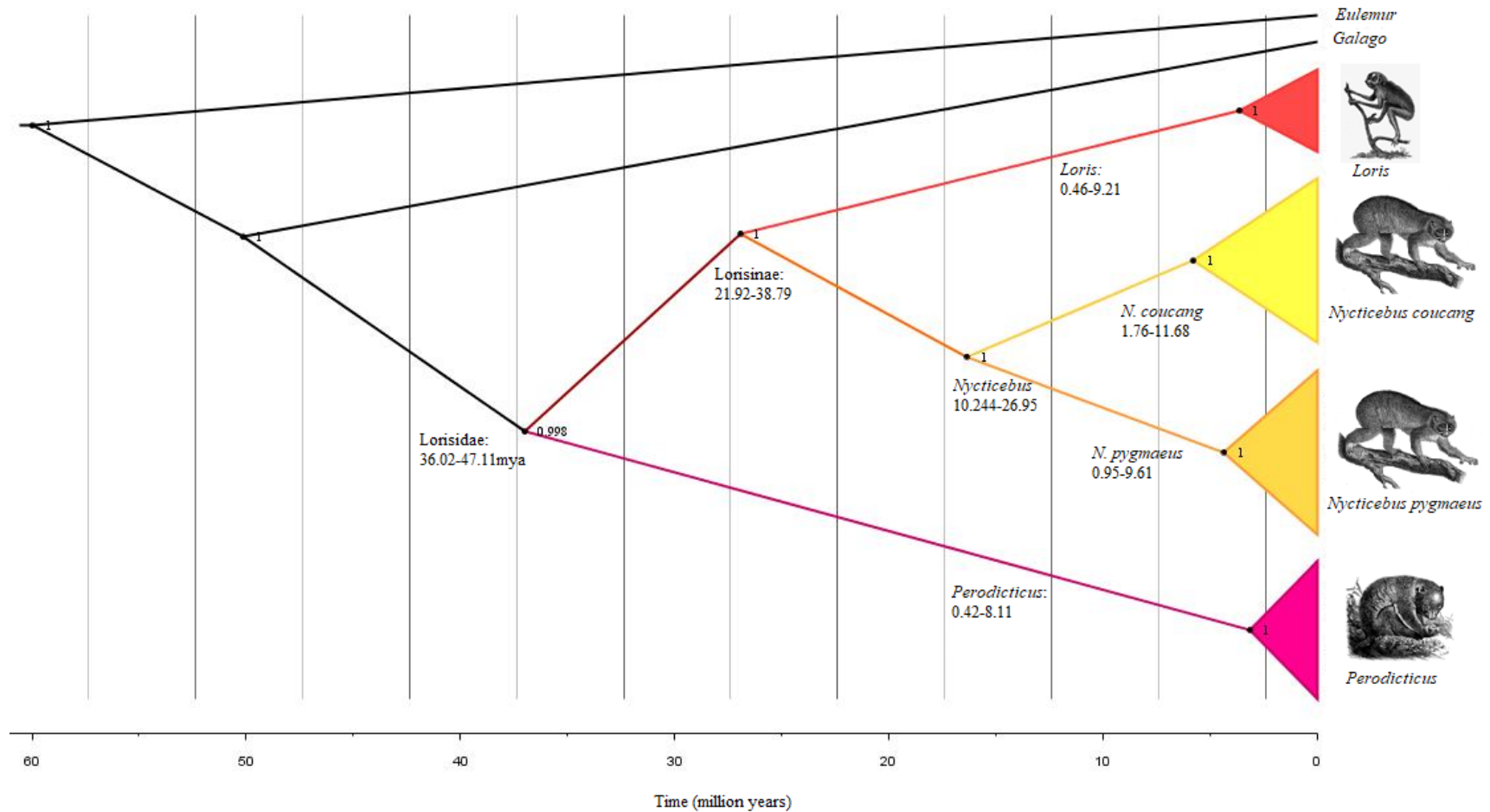

Monophyletic Lorisoidea phylogeny based on concatenated genes (cytochrome *b*, cytochrome oxidase subunit 1, recombinant activation gene 2 intro, and the melanocortin 1 receptor). Nodes show the posterior probability for each clade. Images acquired from the Nash Collection of Primates in Art and Illustration (<http://digital.library.wisc.edu/1711.d1/PCLArts>)